

**NOTE:**

1. COORDINATE LOCATION OF SERVICE CONNECTION WITH THE OWNER, PROPERTY-OWNER AND ENGINEER.

\*TERMINATE NEW SERVICE @ PERMANENT EASEMENT LINE OR RIGHT-OF-WAY LINE WHEN EXISTING SERVICE IS NOT PRESENT

RECONNECT EXIST. SERVICES TO NEW SERVICE CONNECTION WHEN EXIST. SERVICE IS PRESENT. (USE TRANSITION COLLAR WHERE REQUIRED)

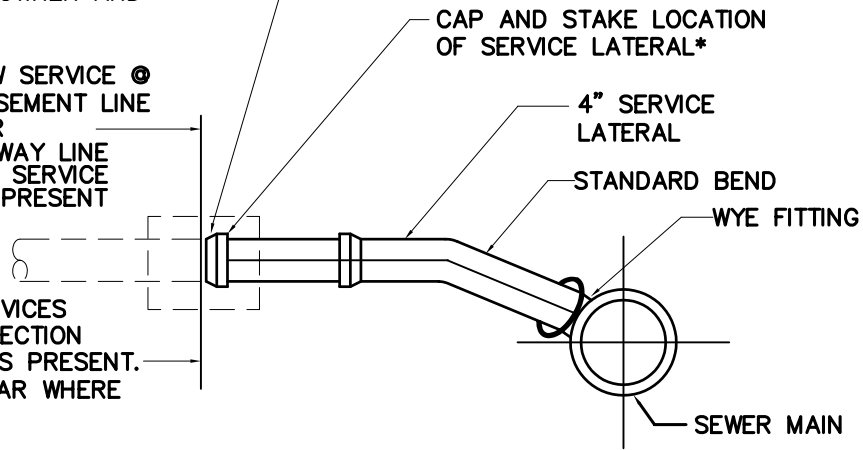

CITY OF FAIRBURN, GEORGIA  
SEWER SERVICE  
CONNECTION

DATE:  
12/29/04  
DETAIL NO.  
S012